

**WORLD CLASS · EFFICIENCY · RELIABILITY**

# k|r|s|v

**ROTARY SCREW VACUUM**



**KAISHAN** | COMPRESSOR  
USA



Kaishan's headquarters for supporting the Americas is located in Loxley, Alabama. The company has made a significant investment in a 130,000-square-foot facility valued at \$26 million.



# KRSV ADVANCED DESIGN FEATURES

## FLEXIBLE

- No matter the application, our vacuum pump is ready to perform at the highest efficiency available on the market

## RELIABLE

- Direct Drive - Eliminates transmission losses
- Simplicity in the design
- Backed by a 5-Year Warranty

## EFFICIENT

- Asymmetric 5 / 6 rotor profile Precision machines rotor technology for tighter clearances and superior performance
- 100% SKF bearings for longer life expectancy averaging 100,000 hours
- Variable Discharge Port for optimized compression ratio

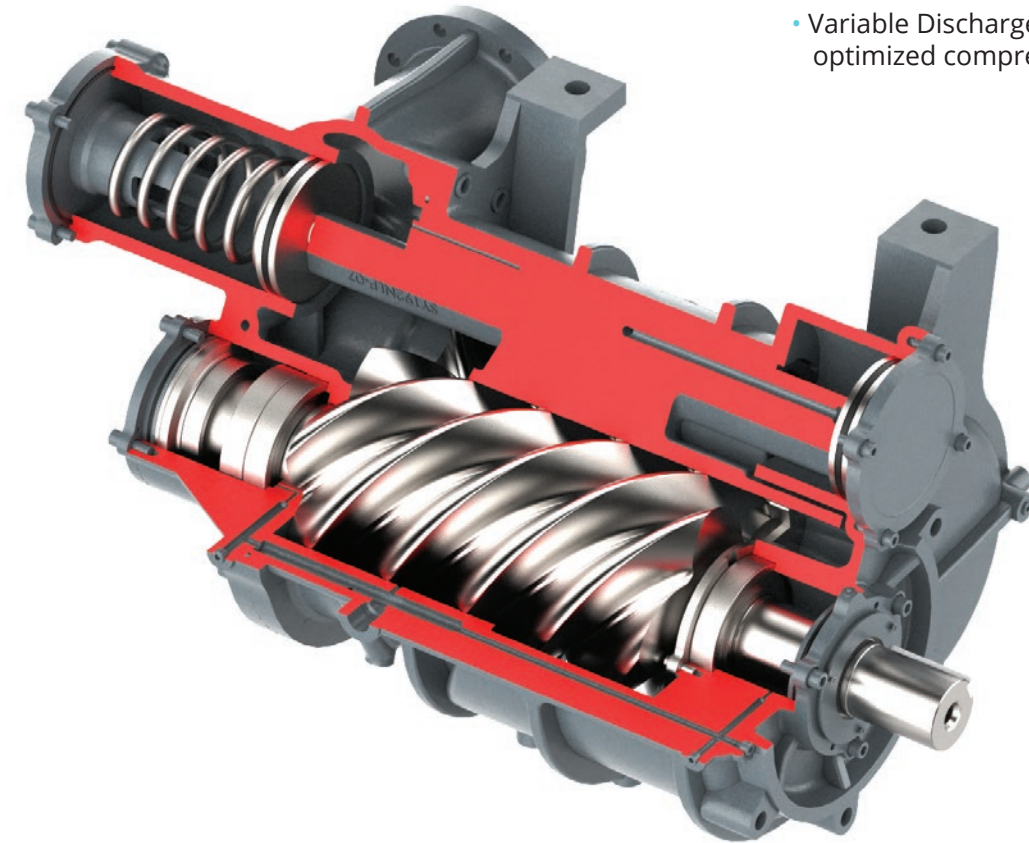

## KAISHAN GROUP GLOBAL PRESENCE

**70+**  
YEARS  
IN BUSINESS

**OVER  
70,000**  
COMPRESSORS  
SOLD ANNUALLY

**3RD LARGEST  
COMPRESSOR MANUFACTURER  
IN THE WORLD**

## KAISHAN KRSV VACUUM PUMP WITH VERSADRIIVE VSD DRIVE

MODEL	POWER		FLOW		SOUND dbA	WEIGHT		SIZE		DIMENSIONS (LxWxH)		MAXIMUM Vacuum Level
	HP	kW	CFM	M3/H		lbs	kgs	inlet	outlet	in	mm	
KRSV-10	10	7.5	286	486	68	2139	970	NPS3	NPS2.5	66x42x44	1676x1067x1118	29.9" HgV
KRSV-25	25	18	800	1359	73	3748	1700	NPS6	NPS4	86x57x65	2184x1448x1651	29.9" HgV
KRSV-30	30	22	982	1668	74	4123	1870	NPS6	NPS4	86x57x65	2184x1448x1651	29.9" HgV
KRSV-50	50	37	1343	2282	76	5909	2680	NPS6	NPS4	98x64x65	2489x1626x1651	29.9" HgV
KRSV-75	75	55	2248	3819	77	8245	3740	NPS8	NPS6	106x75x83	2692x1905x2108	29.9" HgV
KRSV-125	125	90	3505	5955	80	12570	5702	NPS10	NPS8	147x80x94	3734x2032x2388	29.9" HgV

# KRSV ADVANCED PACKAGING

## INTEGRATED HIGH-EFFICIENCY INLET FILTER

### Increased Protection & Energy Savings

- Full airflow, low restriction technology
- Protects your investment
- Increased free air delivery for further savings in energy

## LOW SOUND ENCLOSURE

### As low as 67DbA

- Designed for ease of serviceability

## ADVANCED ELECTRICALS

### Increased Reliability / Lower Servicing Cost

- Worldwide support
- Standard electrical parts available locally.

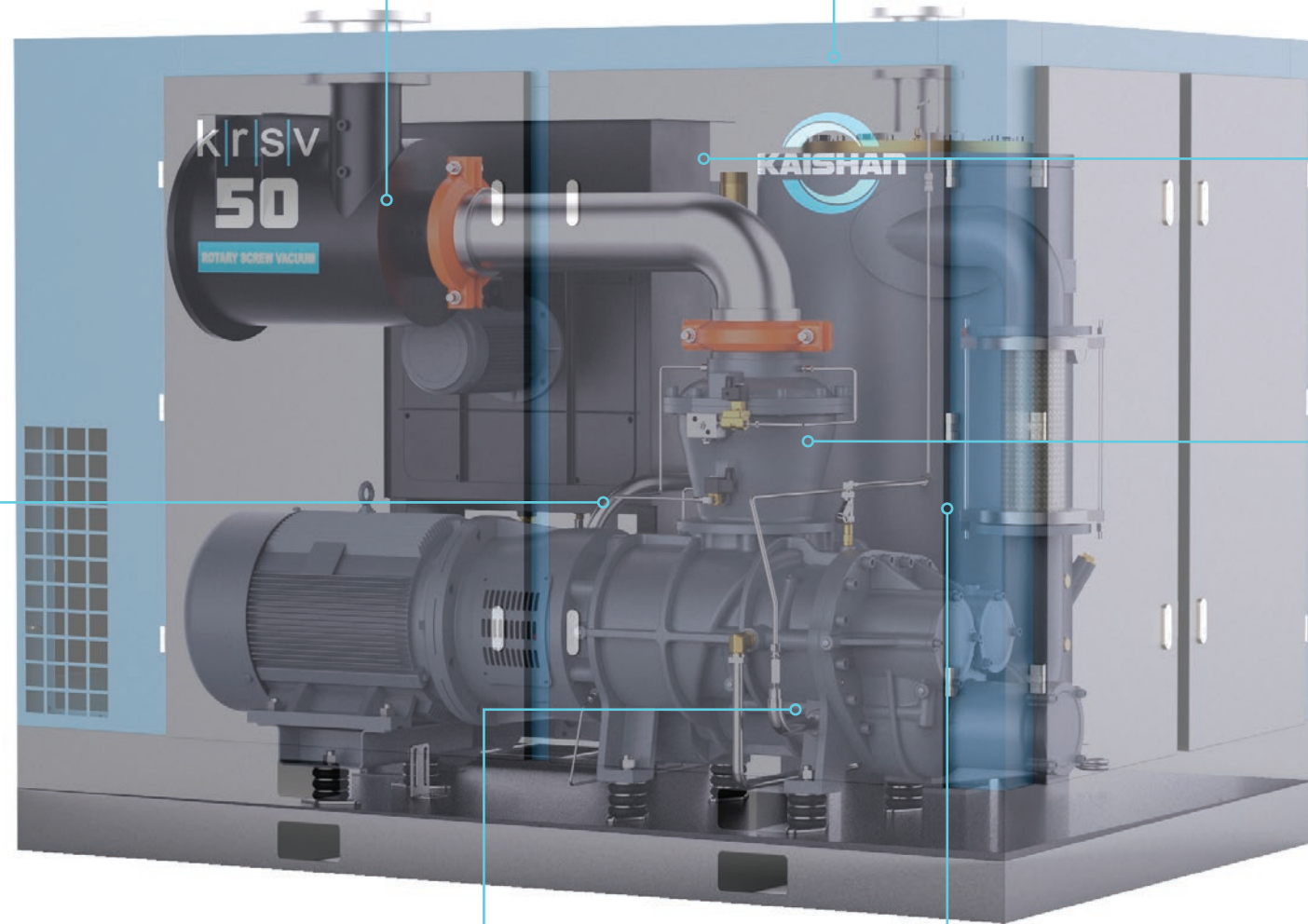

## 316 STAINLESS STEEL CONTROL TUBING AND BRASS FITTINGS

### Long Tubing Life / Reduced Downtime

- Reliability is increased due to indefinite, corrosion-free life.
- Material such as nylon, copper or mild steel will fail in time causing downtime

## SKYv Series Airend

### Variable Discharge Port

- Patented Technology
- Optimizes the volume ratio which allows this vacuum pump to be efficient at any industrial vacuum application.

## THREE STAGE TANGENTIAL OIL SEPARATION

### Lower Pressure Drop / Lower Absorbed Power

- Excellent oil mechanical pre-separation / reduced direct oil impingement onto separator element
- Lower dust contact resulting in lower pressure drop / longer element life / lower energy consumption
- Residual oil carryover limited to 3 ppm



## CAST ALUMINUM OIL COOLER

### Designed and built by Kaishan Compressor

- Increased life expectancy in harsh environments
- Easy to clean and service

## LAMINAR FLOW INLET VALVE

### Minimum Pressure Drop / Increased Output

- Laminar flow inlet valve results in lower pressure drop through the intake, increasing output and saving energy

## WHY IS VARIABLE SPEED DRIVE TECHNOLOGY IMPORTANT IN A VACUUM?

- Standard vacuum pumps use most of the available motor power in the initial stages of bringing the vacuum system down to operational vacuum levels.
- Once at the desired vacuum level, the Kaishan control uses all the available motor power to increase the full load flow, thus providing more flow for the same motor power.
- Custom Kaishan designed controller controls the motor speed and high-efficiency frequency inverter.
- Compressor can start/stop under full pressure without the need to blow down.
- Eliminates peak demand penalty during start-up.

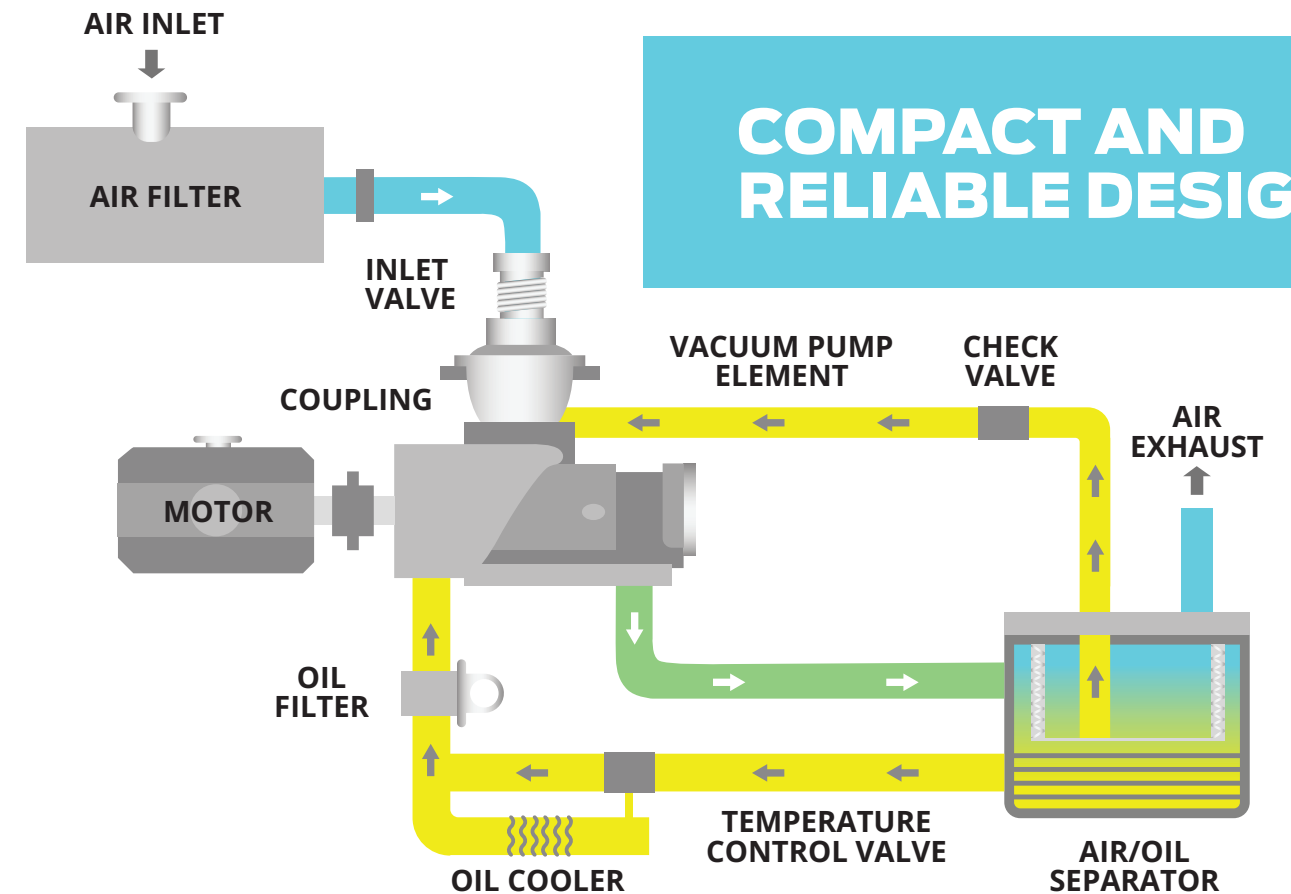

## COMPACT AND RELIABLE DESIGN

# WHY CHOOSE A KAISHAN ROTARY SCREW VACUUM PUMP OVER OTHER TYPES OF VACUUM PUMPS?

## LIQUID RING VACUUM PUMPS

- Use large amount of expensive water
- Need 60-degree water or they will lose capacity
- Are not energy efficient at full load because of pumping action
- Have no part load capabilities and can not unload during downtime

## VANE TYPE VACUUM PUMPS

- Show high CFM at start up but immediately start to lose capacity
- Vanes need to be replaced regularly and can cost 50% of new pump price
- Have no part load capabilities and can not unload during downtime
- Normally have one year or less warranty
- Often run very high into service factor of motor

## TYPICAL ROTARY SCREW VACUUM PUMPS

- Only capable of operating between 15 and 28.5"HgV
- Often not equipped with Variable Speed Drive for maximum part load efficiency
- Normally 40% less CFM than KRSV

## BEST TOTAL COST OF OPERATION KRSV VERSADRIVE WITH STANDARD VARIABLE SPEED DRIVE

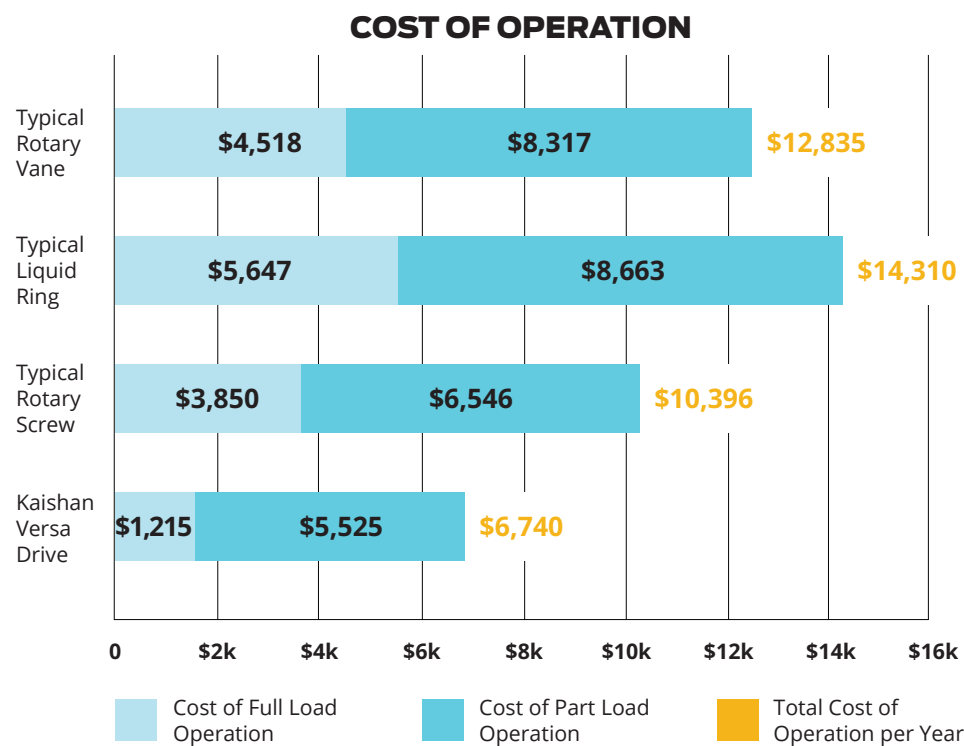

Based on 4000 hours/year, 520CFM at 24"HgV at \$.10/KWH with a 70% average full load



**NORMAL  
PAYBACK  
LESS THAN  
ONE YEAR**

**ASK KAISHAN  
ABOUT A  
- FREE -  
ENERGY  
COMPARISON**

# APPLICATIONS FOR KAISHAN VACUUM PUMPS



Plastic and Injection Molding



Medical

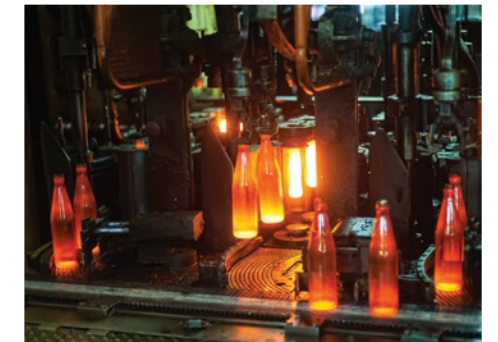

Glass and Ceramics



Woodworking



Food and Beverage



Laboratory and Testing

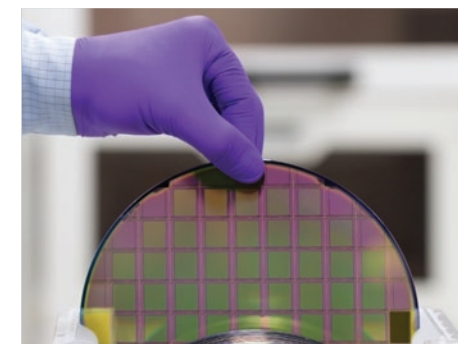

Electronics



Printing



Envelope and Paper



Bulk Conveying



Aerospace



Pharmaceutical



MODEL	COMPRESSOR TYPE	FEATURES
KRSP2	30-600 HP Two Stage	Global leader in air compressor efficiency
KRSP	40-500 HP Single Stage	Patented 'SKY' air end, quadruple SKF bearings
KRSD	15-200 HP Single Stage	Direct drive, TEFC motor, low sound enclosure
KRSB	5-50 HP Single Stage	Belt drive optional tank & dryer packages
KRSL	Single Stage Low Pressure	Pressure as low as 45 PSI
KRSV	Rotary Screw Vacuum Pump	World class vacuum efficiency



[info@KaishanUSA.com](mailto:info@KaishanUSA.com)  
 15445 Industrial Park Dr. · Loxley, AL 36551 USA  
 251.202.0577  
[KaishanUSA.com](http://KaishanUSA.com)